



TROUBLE SHOOTING GUIDE

EVNT4 SERIES



P: 800.942.9199 F: 216.279.0019 www.hospecobrand.com

1. Unit Will NOT Dispense Product

Open the door

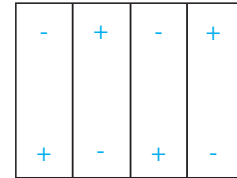
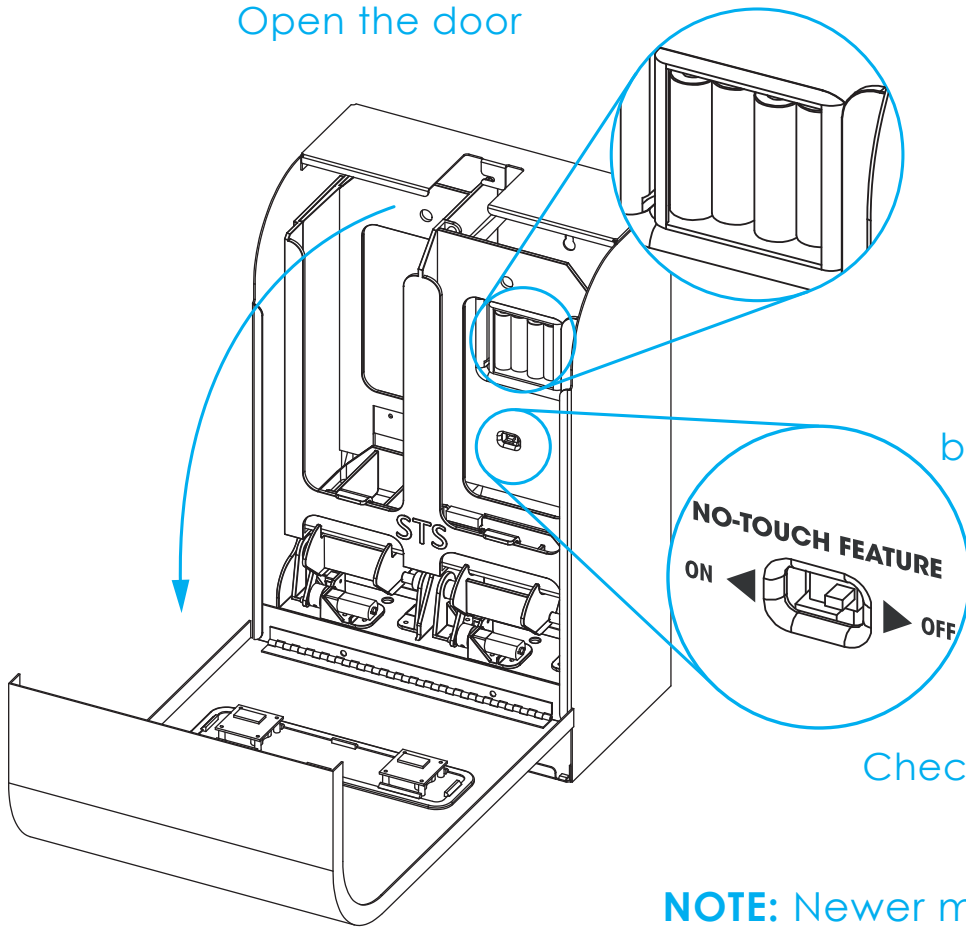

Replace or Check for correct battery orientation. Use only Duracell or Energizer batteries. Replace all at once.

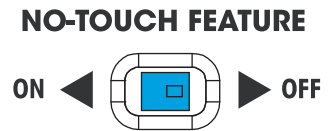

Check Position of Touch Sensor

NOTE: Newer models with Infrared sensors **DO NOT** have this feature

2. Light Indication

Solid Red Lights: [A. Low battery Power \(Replace Batteries\)](#)
[B. Possible Product Jam](#) (SEE PAGE 3)

Blinking Red Lights: [Product is empty Replenish Product](#)

[Remove weights before refill product](#)
[then place weights back on TOP of products](#)

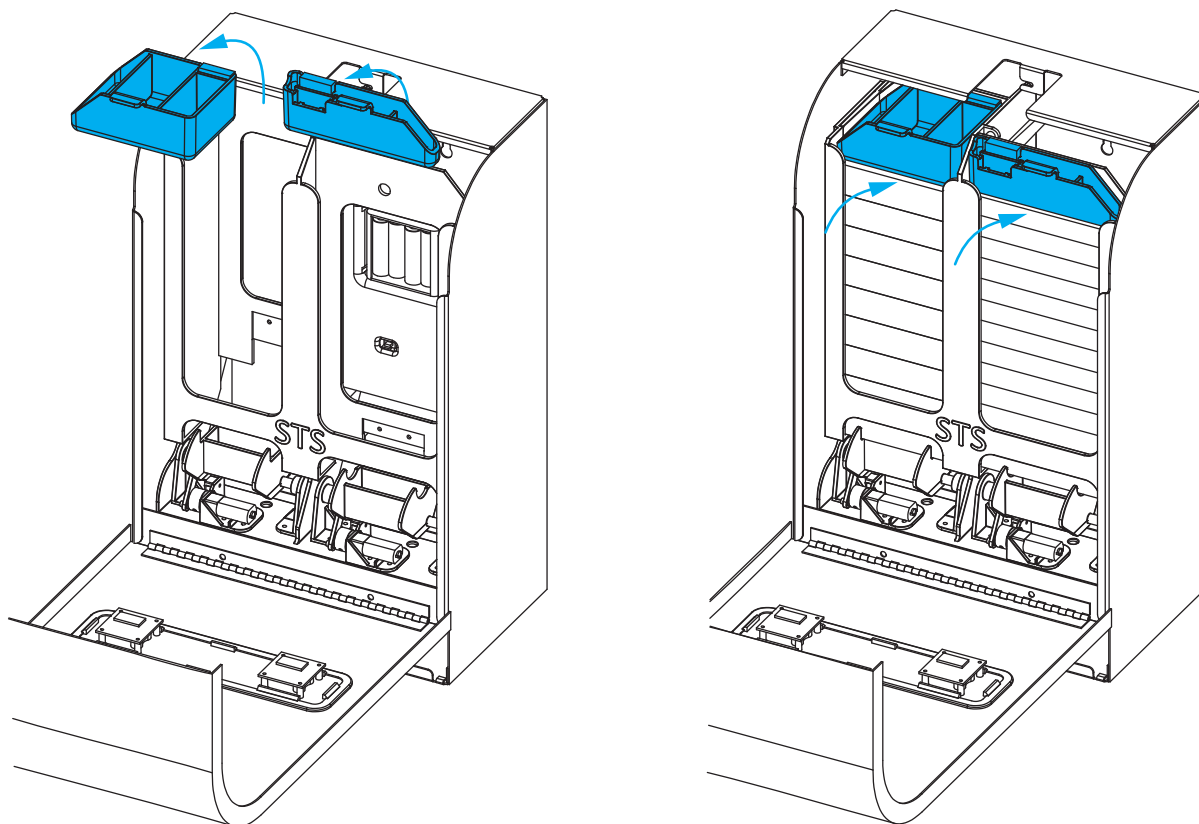

3. Product Jam

Check Napkin Box &
or Tampon Tube to ensure
it Falls Freely in the Channel

Misshaped or oversized
Napkin & Tampons
can cause Jamming

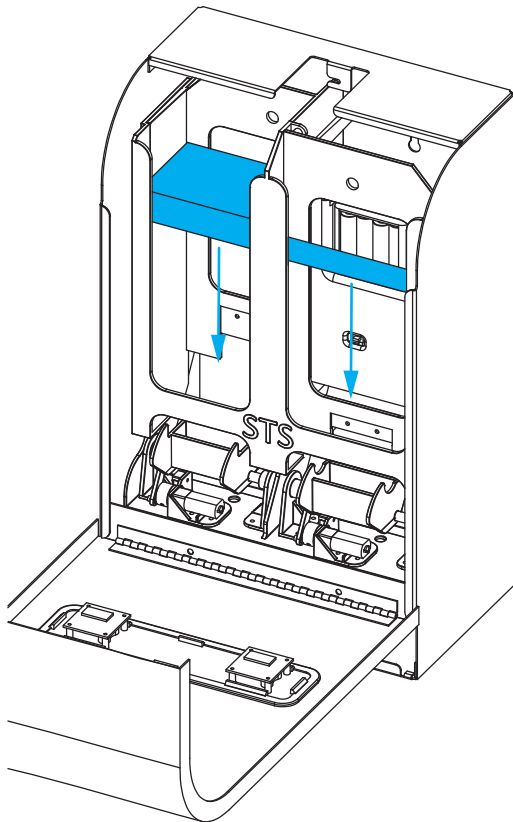

Misshaped



Oversized

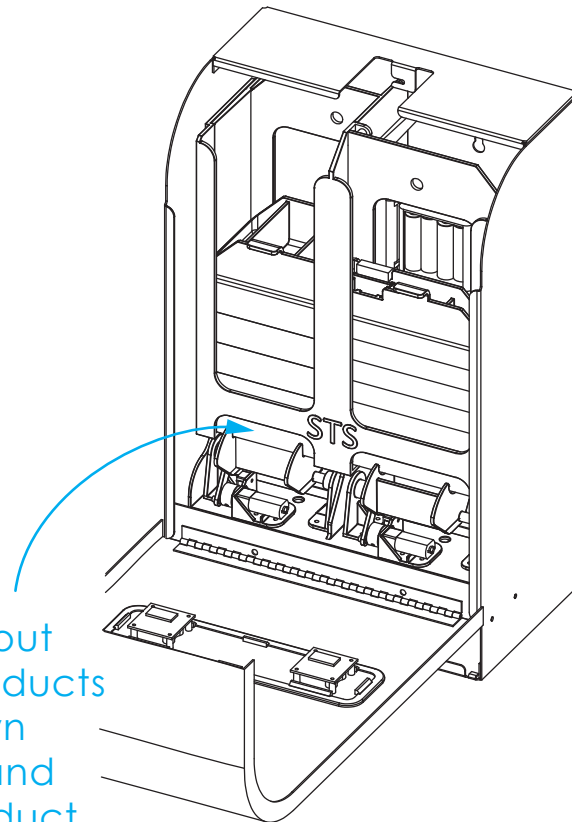

To get the jammed product out
Please remove all remaining products
from the channel, push down
or remove jammed product and
replenish with correct size product

NOTE: DO NOT MANUALLY ROTATE CRADLE